

DRAWING MADE IN THIRD ANGLE PROJECTION

LOC	DIST	REVISIONS					
CE	16	P	F	LTR	DESCRIPTION	DATE	APPROVED
			✓		B REDRAW AND REV PER CE-1199	1-12-88	CE/PLM 1-15-88

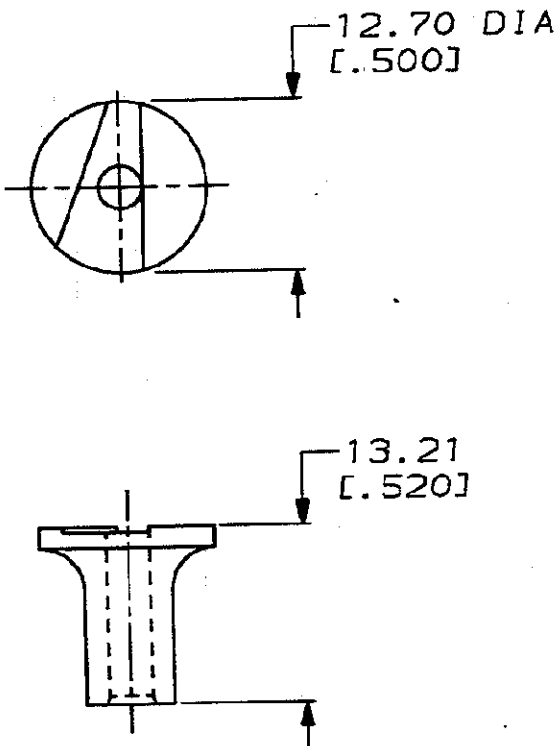

1. DIMENSIONS IN [] ARE IN INCHES

METRIC

228837-1
PART NUMBER

THIS DRAWING IS UNPUBLISHED. RELEASED FOR PUBLICATION BY AMP INCORPORATED. ALL INTERNATIONAL RIGHTS RESERVED. © COPYRIGHT 19

DO NOT SCALE PRINT.
UNLESS SPECIFIED
DIMENSIONS IN MM
TOLERANCES ON:
UN PLC DEC ± .25 (.0102)
UN PLC DEC ± _____
ANGLES ± _____

DR *C. Coughlin* 1-12-88
CHK *[Signature]* 1-14-88
APPR *Robert J. Maguire* 1-15-88
APPR *[Signature]* 1-15-88

AMP

AMP INCORPORATED
Harrisburg, Pa. 17105

MATERIAL
STAINLESS
STEEL

PRODUCT SPEC _____

NAME
CUTTING FIXTURE,
DNP, OPTIMATE

FINISH _____

APPLICATION SPEC _____

SIZE A	FSCM NO 00779	DRAWING NO 228837
------------------	------------------	----------------------

WEIGHT _____

SCALE NTS	SHEET 1 OF 1
--------------	-----------------